

INSTALLATION & OPERATING MANUAL
Insnrg Mi Media Filter

A COMPLETE GUIDE TO YOUR MEDIA FILTER

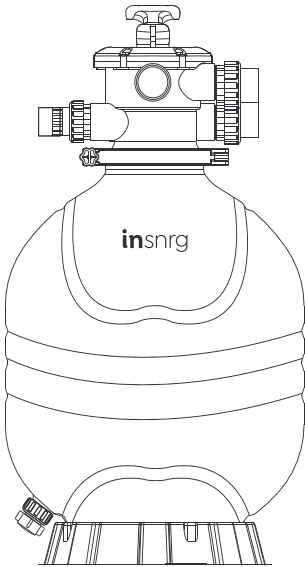

CONGRATULATIONS ON YOUR PURCHASE OF THIS PRODUCT.

THIS MANUAL HAS BEEN CAREFULLY DEVELOPED TO GIVE YOU ALL THE INFORMATION YOU NEED TO GET THE BEST VALUE FROM YOUR PURCHASE.

It is important that you read through the manual to identify the key areas you need to understand, particularly the following:

- Health and Safety Concerns
- Installation requirements
- How to operate the major features of the unit
- The importance of maintenance
- If you have a problem, what to trouble shoot before you contact your professional
- Finally, your entitlements under your product warranty.

Insnrq have developed their product to provide you with the ultimate experience and are sure you will be delighted with your purchase.

Please note: This manual has been designed to cater for installation rules and codes in the USA, Canada and Australia. Specific rules and regulations for each country has been highlighted by the National flag of each country. Please ensure you follow the installation rules specific to your country.

THE IMPORTANT BITS

04 SECTION 1:
We care about your safety

06 SECTION 2:
We want you to be delighted

- Specifications and Dimensions
- Installation
- Start-up Procedure

14 SECTION 3:
Now to Have some Fun

- Multiport Control Valve Functions
- Backwashing
- Winterising

22 SECTION 4:
Oops, something not right?

- Troubleshooting
- Pool Chemistry
- Pro-active Maintenance
- Replacement Parts
- Warranty

SECTION 1

WE CARE ABOUT YOUR SAFETY



IMPORTANT WARNINGS

Warning – read and follow all instructions in this owners manual and on the equipment. Failure to follow instructions can cause severe injury and/or death.

Insnrng highly recommend the installation of all their equipment by a suitably qualified pool professional who will ensure your high performance Insnrng products are installed to your local standards and codes to ensure optimum safety and performance.

CAUTION

All components of the filtration system including Pumps, Filters, Heaters must be positioned so to prevent being used as means of access to the pool by young children. To reduce risk of injury, do not permit children to use or climb on this product. Closely supervise children at all times.



WARNING

Hazardous Pressure. Pool and Spa water circulation systems operate under hazardous pressure during start up, normal operation, and after pump shut off. Stand clear of circulation system equipment during pump start-up. Failure to follow safety and operation instructions could result in violent separation of the pump housing and cover, and/or filter housing and clamp due to pressure in the system, which could cause property damage, severe personal injury, or death. Before servicing pool and spa water circulation systems, all system and pump controls must be in the off position and filter manual relief valve must be in open position. Before starting system pump, all system valves must be set in a position that allows system water to return back to the pool. Do not change filter control valve position whilst system pump is operating. Before starting system pump, fully open filter manual air relief valve. Do not close filter manual air relief valve until a steady stream of water (not air) is discharged.



WARNING

Cleaning the Sand Filter by BACKWASHING and RINSING is essential to providing clean, safe and healthy swimming water. A regular cleaning program is highly recommended especially in Commercial applications, the time between cleans and length of cleaning time will depend on size of pool, bather load and other environmental conditions. Discuss with your local pool professional to work out a program that best suits your pool.

HOW IT WORKS

The Insnrg filter is designed to use filtration sand or other suitable media to remove dirt particles from pool water. The sand or media is loaded into the filter tank to act as the filtration media. Your filter is designed to use 16/30 grade (0.6mm to 1.2mm) sand or suitable glass media. The pool water which contains dirt particles is pumped through your system to the filter via the Multiport Control Valve. As pool water passes through the filter, dirt particles will be caught by the filter bed and removed from the water. The cleaned pool water is returned from the bottom of the Filter Tank, through the Multiport Control Valve and back to the pool through your piping system. The entire process is continuous and automatic. It is this process that provides the filtration and removal of organic material such as dust, dirt and fine particles in your pool water.

During this process, dirt will accumulate in the sand bed and gradually increase the pressure in the tank and reduce the flow of water through your filtration system. This means it is time to clean (BACKWASH) your filter. A good indication when to clean the filter is by checking the pressure gauge reading. Backwash should be performed when you notice the pressure has increased by 5 PSI or 35 kPa from when it was clean.

SPECIFICATIONS AND DIMENSIONS

Model #	Mi 250	Mi 320	Mi 350	Mi 400
Filtration Area (m ²)	0.28	0.28	0.36	0.47
Filtration Area (ft ²)	3.00	3.00	3.88	5.06
Max Flow Rate (litres pm)	250	320	350	400
Max Flow Rate (gallons pm)	66	84	92	105
Turnover Capacity – 8 Hours (Litres)	120,000	153,600	168,000	192,000
Turnover Capacity – 8 Hours (Gallons)	31,680	40,320	44,160	50,400
Sand Required (kg / lbs)	125 / 275	125 / 275	185 / 400	320 / 700
A (mm / inches)	980 / 38.5	1,032 / 40.6	1,133 / 44.6	1,178 / 46.3
B (mm / inches)	860 / 33.8	873 / 34.3	976 / 38.4	1,021 / 40.2
C (mm / inches)	800 / 31.5	807 / 31.8	910 / 35.8	955 / 37.6
D (mm / inches)	280 / 11.0	280 / 11.0	300 / 11.8	370 / 14.6
E (mm / inches)	600 / 23.6	600 / 23.6	675 / 26.6	775 / 30.5

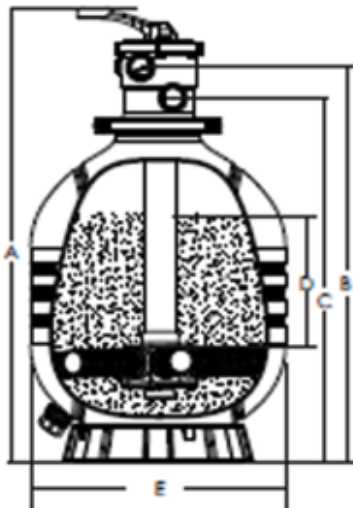

INSTALLATION

The filter should be installed as close to the pool as possible but keep a distance of at least 1.5m (5 feet). Locate the Filter on rigid, level surface, preferably in a dry, shaded, and well-ventilated area. Prior to installation take into consideration the following conditions:

- Position of suction, return, and waste connections
- Access for backwashing operation and servicing
- Protection from sun, rain, splashing, etc
- Drainage of filter room
- Ventilation and protection of the full filtration system

Once you are happy that the above has been considered, follow these steps:

- 1) Place the empty tank in position
- 2) Fill the tank with water to the level that covers the laterals, or about 1/3 of the tank height. This will avoid damage to the laterals by the force of the sand when pouring into the filter.

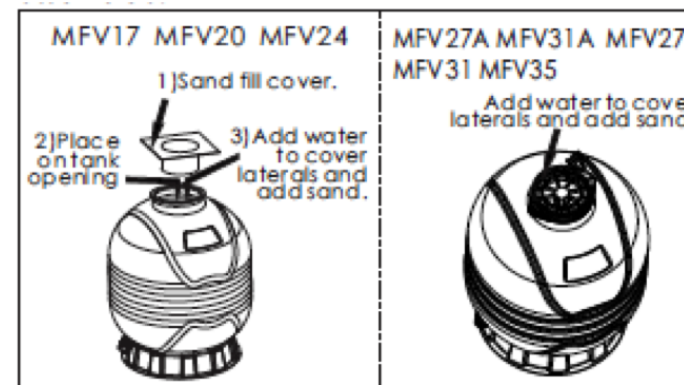

- 3) Pour the recommended amount of sand into the tank, ensuring that the centre-pipe remains centred and vertical
- 4) Level the surface of the sand upon completion
- 5) Remove the Sand Fill Cover
- 6) Carefully remove all sand particles from the valve mounting surface
- 7) Place the O-ring into the groove on the tank
- 8) Lower the Multiport Control Valve carefully into position so that its underside engages with the centre-pipe. Rotate the valve until the inlet is approximately in line with the pump.
- 9) Place the clamp set around the tank and the valve. Secure using the screw provided.
- 10) Firmly tap with a rubber mallet outside of the clamps as you tighten the screw, refer to Figure below
- 11) Tighten the screw until the Multiport Control Valve is properly assembled to create a water tight seal. Do not over tighten.

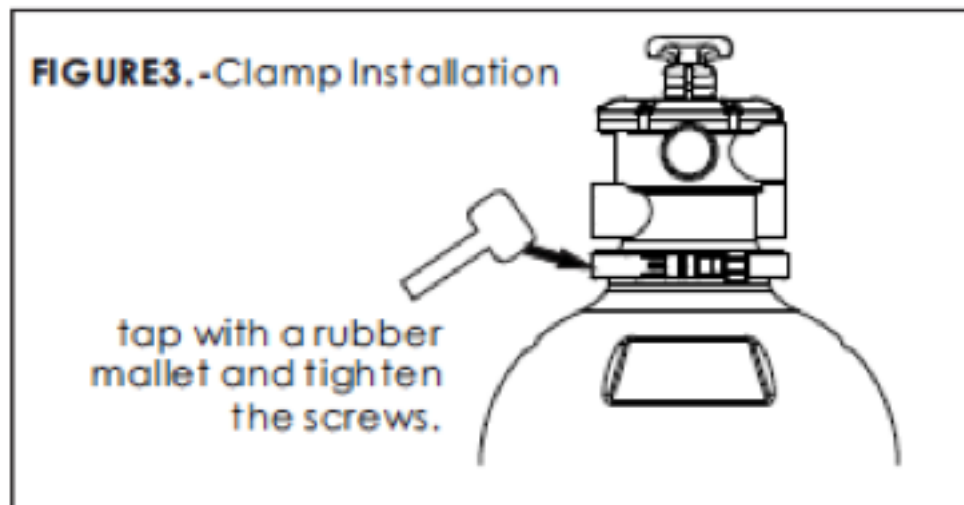

WARNING - Is it important when connecting the WASTE line that you adhere to any local standards and codes in relation to the disposal of the waste water. It is also highly recommended to use minimum 40mm (1.5") PVC Pipe with the MI250 Filter and minimum 50mm (2.0") PVC Pipe with the MI 320, 350 and 400 Filters. To reduce any pressure to provide the best clean possible reduce the distance and amount of bends used for the WASTE discharge line.

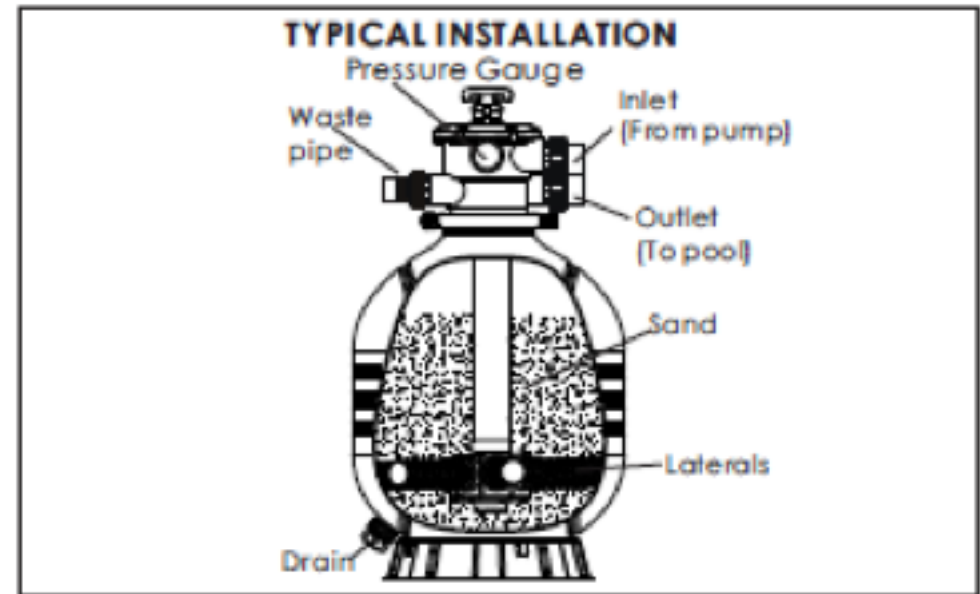

- 17) To prevent water leakage, be sure all pipe connections are tight
- 18) Prior to starting the filtration process by turning on the pump, we highly recommend that you read through the pump instruction manual to ensure proper installation and to avoid the risk of electric shock.

CONGRATULATIONS, YOU HAVE NOW INSTALLED YOUR NEW INSNRG FILTER.

START-UP PROCEDURE

- 1) Be sure the correct amount of filter sand media is in the tank and all connections have been made and are secure.
- 2) Turn the Multiport Control Valve handle to the “Backwash” position. Press the handle downward before turning.
- 3) Start the pump according to pump instruction manual (be sure all suction and return lines are open).
- 4) Once water flow is steady out the waste line, run the pump for at least 2 minutes. The initial backwashing of the filter is recommended to remove any impurities or fine sand particles in the sand media.
- 5) Turn the pump off and set the control valve to RINSE position. Start pump and operate until water in sightglass is clear. Turn pump off, set valve to FILTER position and restart pump. Your filter is now operating in the normal filter mode, filtering particles and dirt from the pool water.
- 6) Take note of the initial pressure gauge reading for future reference. Variation may occur from pool to pool.
- 7) Adjust pool suction and return valves to achieve desired flow. Check system and filter for water leaks and tighten connections, bolts, nuts as required.

NOTE: During the initial clean-up of the pool water, it may be necessary to backwash frequently due to the unusually heavy initial dirt load in the water.

IMPORTANT: To prevent unnecessary strain on piping system and control valve, always turn off the pump before changing the operation of the control valve. To prevent damage to the pump and filter and for proper operation of the system, clean pump strainer (basket) and skimmer basket(s) regularly.

SECTION 3

HAVE FUN AND
GET THE MOST
OUT OF YOUR
PURCHASE

MULTIPOINT CONTROL VALVE FUNCTIONS

The Multiport Control Valve controls the direction of water flow throughout your filter allowing you to easily filter your swimming pool water and then clean your filter tank. Correct operation of the Multiport Control Valve will give you healthy, clean water for many years. It is important to understand the functions of each setting which is explained below.

Please take a moment to read and understand.

1) FILTER

This is the standard position when your filtration system is in normal operation. The water flows in from your pool and is distributed across the top of the sand bed in the filter.

Through pressure this water is pushed down through the Sand allowing debris to be removed from the water and collected in the sand bed. Water is then taken up through the laterals and the centre stem pipe and returned to the pool, usually via some form of sanitation and/or heating. The filter position can also be used for manual vacuuming and cleaning.

2) BACKWASH

This position is used when the sand bed requires cleaning.

Use the Pressure Gauge to indicate when this is required, usually 5 PSI or 35 kPa above operation of a clean filter. When backwash is selected the water flow is reversed and goes down the stem pipe and out through the laterals. This lifts the sand bed and allows debris to be taken up the filter and out through the waste pipe. The sight glass will show the quality of the water and you need to backwash until this water is clear.

3) WASTE

The waste position allows you to pump excess water from the pool directly down the waste pipe. This position is useful after heavy rains where the water level is too high. Water is directed straight through the Multiport Control Valve and bypasses the filter, going directly to waste. You can also use this position to vacuum heavy concentration of debris from

the pool.

4) RECIRCULATE

Similar to the Waste setting, Recirculate allows the water to bypass the filter but goes straight back to the pool. This is a useful setting if you have applied some chemicals that need to be circulated, but not removed by the filter. In addition, if a leak develops in the filter use recirculate to continue circulating water until it is fixed.

5) RINSE

Rinse is a very important setting to use after you have completed the Backwash cycle. In the Rinse setting, water is taken from the pool and distributed on the sand bed. This downward flow settles the sand bed after backwashing and carries any remaining loose dirt through to the waste line. By using Rinse after Backwashing you will eliminate any debris returning to the pool water. Rinse until you see clear water in the Sightglass and should take half the time of a Backwash cycle.

6) CLOSED

Closed setting acts like a Valve and prevents flow of water through the Tank, particularly useful if doing any maintenance on the filtration system.

BACKWASHING YOUR FILTER

Cleaning your Filter will give you the best quality swimming water that is clean, clear and safe for swimming. It is highly recommended to clean on a regular basis and to monitor the pressure gauge and BACKWASH when an increase of 5 PSI or 35 kPa is indicated from your clean filter.

TO PERFORM THE BACKWASH OPERATION YOU MUST FOLLOWING THESE STEPS:

1. Turn off Pump
2. Change the position of the Multiport Control Value handle from FILTER to BACKWASH
3. Turn Pump back on. The water flow is automatically reversed through the Filter so the water is directed from the bottom of the tank, up through the sand, flushing the trapped dirt and debris out of the waste line.
4. Check Sight Glass. The duration of the backwash operation will depend on how dirty your filter is. Continuously check the sight glass to see when the water becomes clear, then
5. Turn off Pump
6. Change the position of the Multiport Control Value handle from BACKWASH to RINSE.

7. Turn Pump back on. The water flow will now be directed back through the Sand bed and then out through the waste line. This will settle the sand bed back for normal operation.

8. Check Sight Glass. Continue until water in Sight Glass is clear, usually about half the time of the backwash cycle.

9. Turn off Pump

10. Change the position of the Multiport Control Value handle from RINSE to FILTER.

11. Turn on Pump



WARNING

Turn off the pump before switching the control valve handle.



WARNING

Cleaning the Sand Filter by BACKWASHING and RINSING is essential to providing clean, safe and healthy swimming water. A regular cleaning program is highly recommended especially in Commercial applications, the time between cleans and length of cleaning time will depend on size of pool, bather load and other environmental conditions. Discuss with your local pool professional to work out a program that best suits your pool.

WHEN VACUUMING THE POOL

If using your Manual Vacuum System to clean the pool. The following can be used as a guide for settings on your Multiport Control Valve.

- A)** Light Soil, general clean - set the control valve to FILTER position

- B)** Heavy Soil, specific clean - set the control valve to WASTE position. If using the WASTE position, ensure that the pool water level is well above your skimmer box level as the water will be directed down the waste line.

WHEN WINTERISING YOUR FILTRATION SYSTEM

Winterising is preparing your pool for freezing conditions which can potentially damage all pool filtration equipment due to water expanding when frozen. We highly recommend the following steps when preparing your filter for winter conditions:

- 1.** Backwash the filter for at least thirty minutes before closing down the pool for winterising. This will clean the filter bed thoroughly and remove any debris from the system.

- 2.** Drain the filter tank by removing the drain cap at the base of the filter tank. Leave the cap off during winter.

- 3.** Set the control valve handle between the RINSE and FILTER. This will lift the handle and help with the draining process by allowing air to enter into the tank.

- 4.** Unscrew the pressure gauge from the control valve and store the gauge indoors.

- 5.** Drain and winterise pump according to pump instructions.

- 6.** This is an ideal time for any repairs that may be required during the off-season. Most pool professionals will recommend what is needed before the next pool season.

SECTION 4

OOPS, SOMETHING'S NOT RIGHT?

Maintenance, Trouble Shooting,
Replacement Parts, Warranty &
Contact Section

TROUBLESHOOTING

The chart below identifies some of the main issues you may encounter with your sand filter. This should assist with the majority of problems. Insnrq highly recommends regular checks and maintenance of your swimming pool equipment by a qualified pool professional. This will extend the life of your equipment and give you the best performance.

PROBLEM	SOLUTIONS
Sand Entering the Pool	<ul style="list-style-type: none"> -Sand too small and getting through Laterals -Flow rate on Pump is too high and pushing sand through Laterals -Sand Bed Calcified due to poor water chemistry -Broken Lateral -Loose Centre-Pipe -Too much Sand in Tank -Multiport Control Valve not correctly in Filter position -Too much Air in Filter
Sand coming out of Waste Line	<ul style="list-style-type: none"> -Flow rate on Pump is too high and lifting Sand too high on Backwash
Pool Water is Cloudy due to poor Filtering	<ul style="list-style-type: none"> -Sand Bed is dirty and requires Backwashing -Incorrect Sand has been installed -Sand Bed is too low -Algae build-up in Filter due to poor water chemistry -Excessive dirt in pool -Calcified Sand Bed due to poor water chemistry -Heavy Swimmer Load -Flow rate on Pump is incorrect for Filter size and Pool size -Backwashing Cycle is too Short -Backwash line is too small restricting water flow
Filter Leaking Water	<ul style="list-style-type: none"> -Tank Cracked -Drain Plug not tight -Valve to Tank O-ring damaged
Multiport Control Valve Leaks	<ul style="list-style-type: none"> -Handle is not properly located in selected setting -Valve to Tank O-ring damaged -Valve Cover O-ring damaged -Pressure Gauge O-ring damaged

PROBLEM	SOLUTIONS
Abnormal Loss of Pool Water	-Leak inside Control Valve -Leak from Pool or PVC Piping
High Pressure Filter	-Filter requires Backwashing -Calcified Sand Bed due to poor water chemistry -Return lines too small for flow rate of Pump
Low Pressure in Filter	-Multiport Control Valve incorrectly set -Pump Flow Rate is too slow, check speed and other control valves -Air leak in Pump Suction

NOTE: If the recommendation in this manual does not solve your particular problem(s), please contact your local dealer for service.

POOL CHEMISTRY GUIDELINES

To get the best performance out of any of your pool equipment, it is important that you manage your water chemistry to the ideal swimming levels. This could vary according to your location and Insnrng highly recommend that you employ the services of your local pool professional to get your pool set-up to exactly what is required. The below chart gives some guidelines to the major water chemistry areas to provide the best performance and to maximise your equipment life. Should your chemistry fall outside the suggested ranges, this could be damaging to the equipment and its performance.

IMPORTANT POOL CHEMISTRY LEVELS	RANGE
pH	7.2 to 7.6
Total Alkalinity	100 to 130 ppm
Total Chlorine	1.0 to 3.0 ppm
Stabiliser (Cyanuric Acid)	40 to 70 ppm
Salt / Mineral	Max 5,000 ppm

PRO-ACTIVE MAINTENANCE PROGRAM

Like your motor vehicle it is important to maintain a regular service program for your pool equipment to ensure the best operation and long lasting results. The below chart provides a guideline to follow to best look after your valuable equipment. Regular maintenance can identify any potential issues early and save on expensive maintenance at a later date.

WHEN?	WHAT ARE YOU LOOKING FOR?	HOW CAN YOU FIX?
Weekly	Check Pressure Gauge.	If pressure increases by 5 PSI / 35 KPA, then BACKWASH and RINSE the filter as per instructions.
Quarterly	Check all Gaskets & Pressure Gauge	Isolate and turn off the Pump. Remove all Gaskets and turn over. You can also apply a silicon based grease to extend the life. If dry, then contact your local pool professional to replace.
	Check around the unit for leaves/debris or signs of flooding.	Replace any debris that is restricting air circulation around the Filter. If in a flood prone location, rectify.
	Check for any Insects/Ants etc	It is a good practice to use a good quality surface spray around your equipment. Make sure all units are turned off and then spray around all units to eliminate any insect/ants etc
	Check for any leaks	If you notice any water leaking from the filter or other equipment. Check gaskets first and reseal. If continues, contact your local pool professional to assess and rectify.

REPLACEMENT PARTS OF FILTER

Key No.	Part No.	Description	Qty
1	88281550B	6 Way 1.5" Valve with 1.5" union set x3 and pressure gauge (Black)	1
1	88281551B	6 Way 2" Valve with 2" union set x 3 and pressure gauge (Black)	1
2	06021013	Plastic Pressure Gauge with O-Ring	1
2	01111048	Connector for Pressure Gauge/Stopper	1
3	89280102B	1.5" union set (Black) with O-ring	3
3	89280102W	1.5" union set (White) with O-ring	3
3	89280103B	2" union set (Black) with O-ring	3
3	89280103W	2" union set (White) with O-ring	3
4	03021035	M6 Nut	1
5	89012512	Clamp Kit	1
6	01111101	Star-Shaped Nut	1
7	03011166	M6x110mm Screws	1
8	02010007	O-Ring	1
9	89012501	Filter Tank for MFV17	1
9	89012502	Filter Tank for MFV20	1
9	89012503	Filter Tank for MFV24	1
9	89012504	Filter Tank for MFV27/MFV27A	1
9	89012505	Filter Tank for MFV31/ MFV31A	1
9	89012506	Filter Tank for MFV35	1
10	89012507	Lateral Assembly with Center Pipe for MFV17	1
10	89012508	Lateral Assembly with Center Pipe for MFV20	1
10	89012509	Lateral Assembly with Center Pipe for MFV24	1
10	89012510	Lateral Assembly with Center Pipe for MFV27A	1
10	89012513	Lateral Assembly with Center Pipe for MFV27	1
10	89012511	Lateral Assembly with Center Pipe for MFV31A	1
10	89012514	Lateral Assembly with Center Pipe for MFV31	1
10	89012515	Lateral Assembly with Center Pipe for MFV35	1
11*	01172007	Laterals (115mm)	*
11*	01172008	Laterals (126mm)	*
11*	01172010	Laterals (185mm)	*
12	89011601	Water Drain Set	1
13	01111059	16-21inch Filter Base	1
13	01111062	21-28inch Filter Base	1
13	01112037	31-35inch Filter Base	1

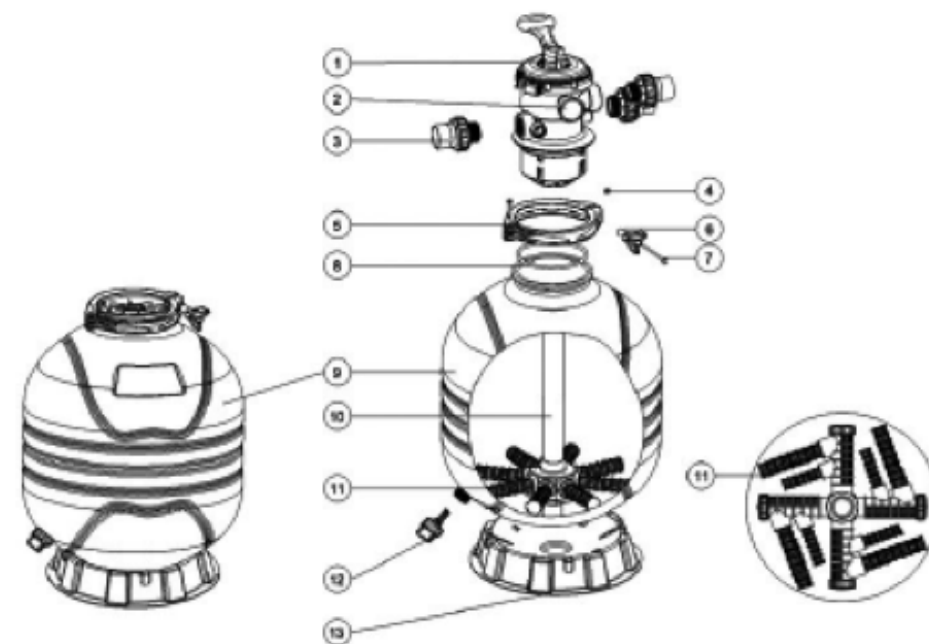

WARRANTY

Insnrng products are designed and manufactured to the highest possible standards of performance.

Australian Consumer Law

Our goods come with guarantees that cannot be excluded under the Australian Consumer Law. You are entitled to a replacement or refund for a major failure and for compensation for any other reasonably foreseeable loss or damage. You are also entitled to have the goods repaired or replaced if the goods fail to be of acceptable quality and the failure does not amount to a major failure.

Warranty Period and Conditions

Insnrng Techne Pty. Ltd. (hereinafter “the Company”) is pleased to warrant to the original retail purchaser that this product shall be free of manufacturing and material defects for a period of five (5) years from the original invoice date subject to the following conditions:

1. The product is purchased new from an authorised Insnrg dealership in Australia, New Zealand or North America.
2. This warranty is not assignable and applies to the original retail purchaser only and the original receipt, invoice or any other proof of purchase must be retained and produced if requested by the Company.
3. Nothing in this warranty shall apply to any defects caused by misuse or abuse, neglect, accident, extremes of climate, dampness, humidity, reasonable fair wear and tear and/or any causes other than defects in manufacturing and materials. Proper care and maintenance information is detailed in the Owner’s Manual for this product which you must follow.
4. Where a defect is physically visible or otherwise affects the exterior surfaces of the product, you must notify the Company of such defect within fourteen (14) days from the date of your purchase.
5. If the product is bought as a demonstration, refurbished, ex-rental, discontinued or otherwise previously unboxed unit, the warranty applicable shall be limited to twelve (12) months only.

Warranty Claim Procedure

To exercise your rights under this warranty, you must:

Within fourteen (14) days of you becoming aware of any defect, report the following details to the dealership from which the product was purchased:

- Your name, address and contact information;
- Model, and serial number of the product; and
- A detailed description of the defect.

On receipt of the above information, the Company will allocate to your dealership an Insnrg Authorisation Number (IAN).

Depending on the model type, how it is installed, and the defect reported, your nominated dealership will advise on how the warranty service will be performed. This could include, but not limited to, return of product to the dealership, return of product to the company, or a visit by qualified service technician to your poolside.

If advised to return the product, place the defective product in secure packaging, clearly label it with the IAN number allocated and send it to the address of the authorised service agent which will be advised by your dealership.

The Company will not be liable for any transportation costs, or in the event that a poolside call is arranged with an authorised service technician, costs of technician’s travel time if the defect is found not to be covered by the consumer guarantees.

In the case of returned product, the authorised service technician or dealership will contact the purchaser when the product has been repaired and is ready for collection.

The Company will repair or replace at its absolute discretion your product at no cost for parts or labour in accordance with the terms stated in this warranty provided that the reported defect is able to be located by the technical staff assigned to the product. If the technical staff is unable to locate the defect, you may be liable to pay for the cost of the technician’s travel time and labour.

A large, solid orange shape on the left side of the page, starting from the bottom and curving upwards at the top.

insnrg

PRODUCTS IN PERFECT SYNERGY